

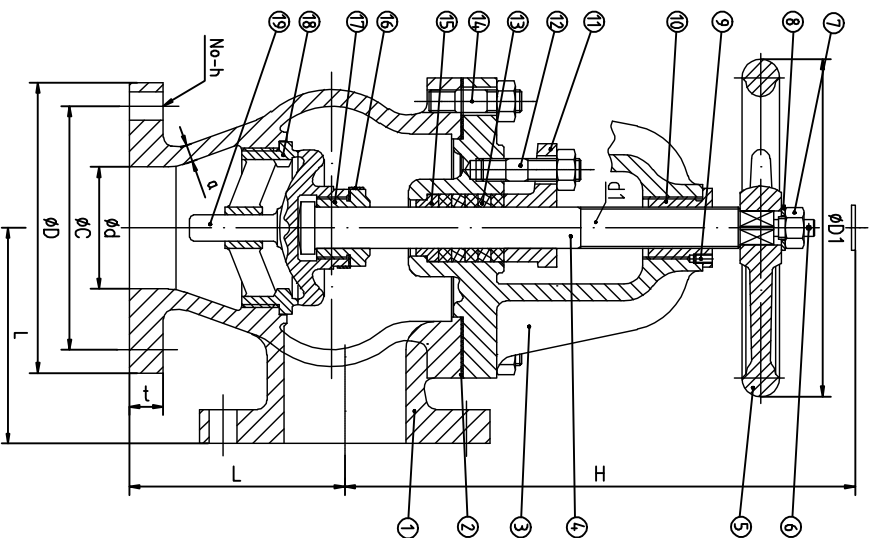

Marine Cast Iron Angle Valves 16K



DN	d	L	D	C	No-h	t	H	D1	d1	a
50	50	120	155	120	8-19	20	255	160	Tr-22	10
65	65	130	175	140	8-19	22	270	200	Tr-24	11
80	80	150	200	160	8-23	24	295	224	Tr-26	12
100	100	170	225	185	8-23	26	330	250	Tr-30	13
125	125	200	270	225	8-25	26	390	315	Tr-36	15
150	150	225	305	260	12-25	28	435	355	Tr-42	16
200	200	250	350	305	12-25	30	540	450	Tr-48	19

Technical Specification

Nominal Pressure	Spec	Strength testing pressure	Seat testing pressure
16K	50K-200K	3.3MPa	2.42MPa

19	Disc	2C-13	
18	Sealing Ring	2C-13	
17	Disc Nut	2C-13	
16	Check Washer	H62	
15	packing seat	H62	
14	Double Open end Bolt	Q235A	
13	Packing	Expanded graphite	
12	Double Open end Bolt	Q235A	
11	Gland Packing	2C-13	
10	Screwed Bonnet Bush	H62	
9	Screw	Q235A	
8	Gasket Ring	Q235A	
7	Nut	Q235A	
6	Split Pin	A3	
5	Handwheel	HT200	
4	Stem	2C-13	
3	Cover	HT200	
2	Asbestos Free	Expanded graphite	
1	Body	HT200	
NO.	Description	Material	Remark

Design		Fukewei	Review	Sign	Date
Calibrator		Fukewei	Approver		
Process			Date	2014.12	
DRAWING			JIS 7310-16K		
A total of 1 first			Note	QTY	Proportion
Qingdao V-good Marine Valve Manufacturing Co.,LTD.					