

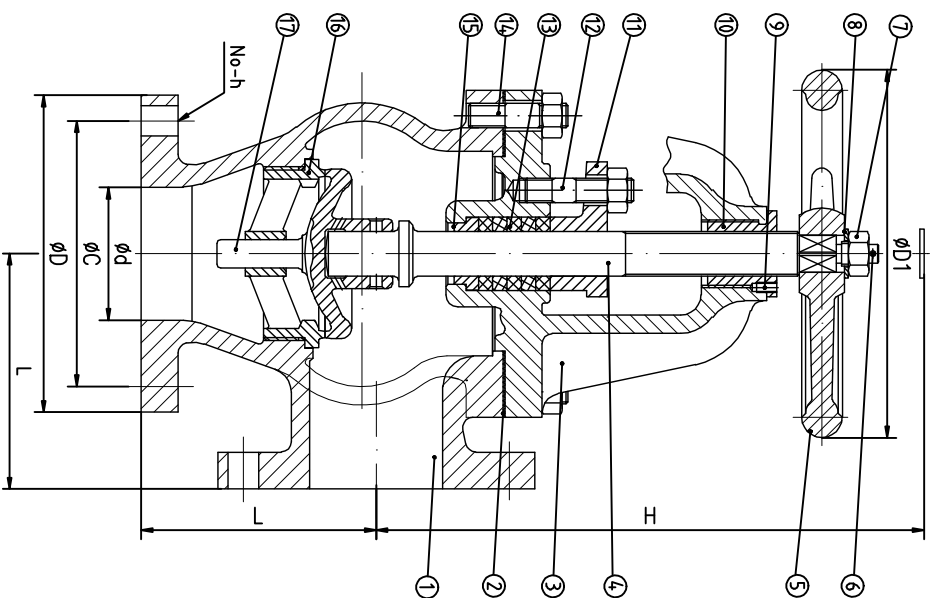

Marine Cast Iron Screw Down Check Angle Valves 10K



DW	d	L	D	C	No-h	t	H	D1	d1	a
50	50	120	165	120	4-19	20	265	160	Tr-22	10
65	65	130	175	140	4-19	22	260	200	Tr-24	11
80	80	140	185	160	8-19	22	270	200	Tr-24	11
100	100	160	210	175	8-19	24	305	250	Tr-28	12
125	125	180	250	210	8-23	24	350	280	Tr-32	13
150	150	205	280	240	8-23	26	390	315	Tr-36	14
200	200	230	330	290	12-23	26	450	355	Tr-42	17

Technical Specification

Nominal Pressure	Spec	Strength testing pressure	Seat testing pressure
10K	50A-200A	2.1MPa	1.5MPa

17	Disc	2C-13	
16	Sealing Ring	2C-13	
15	packing seat	H62	
14	Double Open end Bolt	Q235A	
13	Packing	Expanded graphite	
12	Double Open end Bolt	Q235A	
11	Gland Packing	2C-13	
10	Screwed Bonnet Bush	H62	
9	Screw	Q235A	
8	Gasket Ring	Q235A	
7	Nut	Q235A	
6	Split Pin	A3	
5	Handwheel	HT200	
4	Stem	2C-13	
3	Cover	HT200	
2	Asbestos Free	Expanded graphite	
1	Body	HT200	
NO.	Description	Material	Remark

JIS 7376-10K			A total of 1 first
Note	QTY	Proportion	
DRAWING			
Design	Fukewei	Review	
Calibrator	Fukewei	Approver	
Process		Date	2014.12
QingDeo V-gate Marine Valve Manufacturing CO.,LTD			