

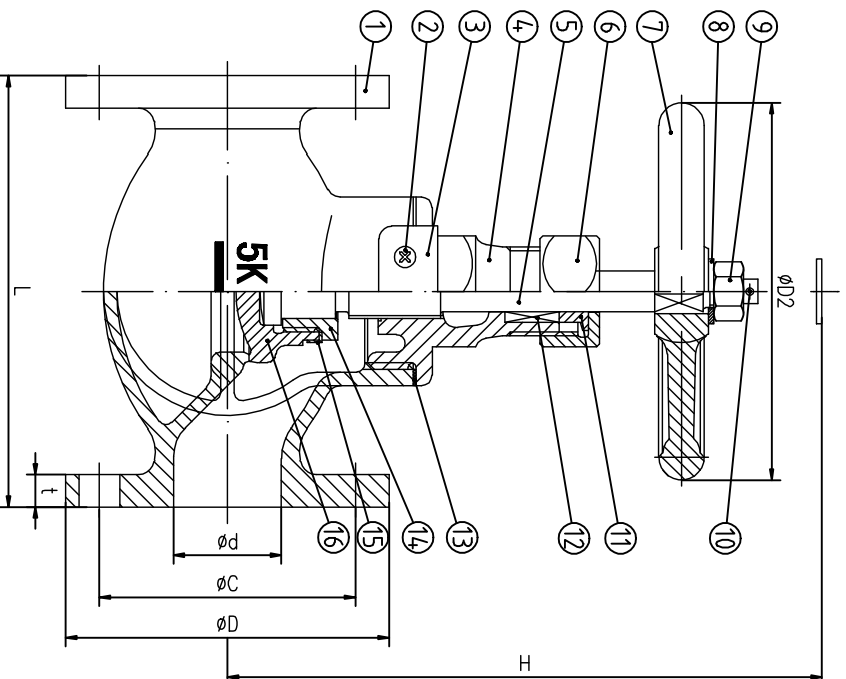

Marine Bronze Globe Valves 5K

Technical Specification

Nominal Pressure	Strength testing pressure	Seat testing pressure
5K	1.05MPa	0.77MPa



DN	d	L	D	C	No-h	t	H	DI	d1	a
15	15	100	80	60	4-12	9	130	80	T-14	3
20	20	110	85	65	4-12	10	140	100	T-16	4
25	25	120	95	75	4-12	10	160	125	T-18	4
32	32	140	115	90	4-15	12	170	125	T-18	4
40	40	160	120	95	4-15	12	190	140	T-20	5
50	50	210	130	105	4-15	14	235	140	T-22	6
65	65	250	155	130	4-15	14	260	160	T-24	7

16	Disc	H62	
15	Gasket	H62	
14	Disc Nut	H62	
13	Asbestos Free	Expanded Graphite	
12	Graphite Packing	Expanded Graphite	
11	Gland Packing	H62	
10	Split Pin	A3	Electroplating yellow
9	Nut	Q235A	Electroplating yellow
8	Gasket Ring	Q235A	Electroplating yellow
7	Handwheel	HT200	
6	Gland nut	H62	
5	Stem	H62	
4	Cover	ZCuSn5Pb5Zn5	
3	Check Washer	H62	
2	Screw	Q235A	Electroplating yellow
1	Body	ZCuSn5Pb5Zn5	
No.	Description	Material	Remarks

JIS 7301-5K			
A total of 1 first			
Note	QTY	Proportion	
DRAWING			
Design	Fukewei	Review	
Calibrator	Fukewei	Approver	
Process		Date	2015.17