

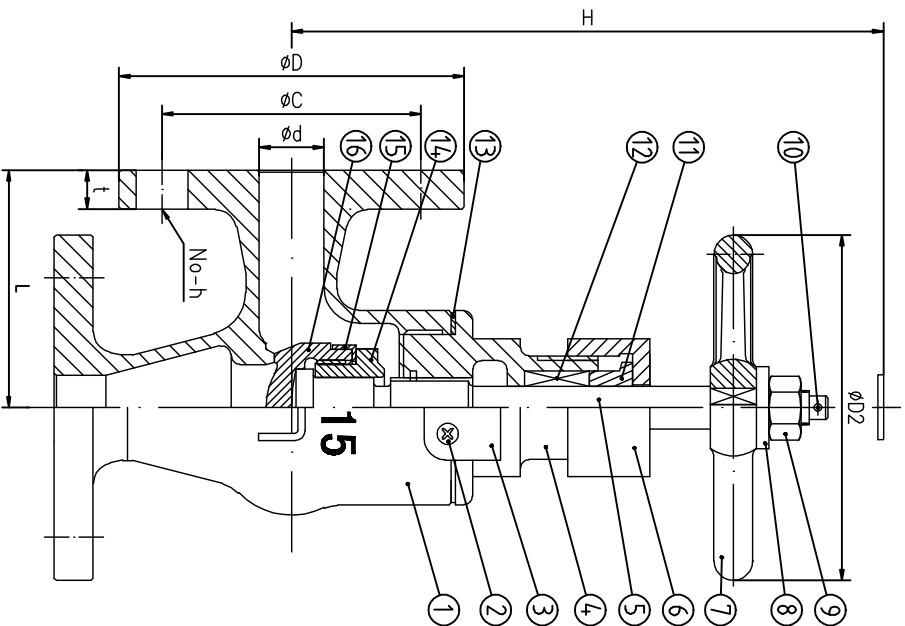

Marine Bronze Angle Valves 5K



DN	d	L	D	C	No-h	t	H	DI	dI	a
15	15	55	80	60	4-12	9	120	80	Tr14	3
20	20	60	85	65	4-12	10	130	100	Tr16	4
25	25	65	95	75	4-12	10	145	125	Tr18	4
32	32	80	115	90	4-15	12	150	125	Tr18	4
40	40	85	120	95	4-15	12	165	140	Tr20	5
50	50	100	130	105	4-15	14	200	140	Tr22	6
65	65	115	155	130	4-15	14	220	160	Tr24	7

Technical Specification

Nominal Pressure	Strength testing pressure	Seat testing pressure
5K	1.05MPa	0.77MPa

16	Disc	H62	
15	Gasket	H62	
14	Disc Nut	H62	
13	Asbestos Free Graphite Packing	Expanded Graphite	
12	Graphite Packing	Expanded Graphite	
11	Gland Packing	H62	
10	Split Pin	A3	Electroplating yellow
9	Nut	Q235A	Electroplating yellow
8	Gasket Ring	Q235A	Electroplating yellow
7	Handwheel	HT200	
6	Gland nut	H62	
5	Stem	H62	
4	Cover	ZCuSn5Pb5Zn5	
3	Check Washer	H62	
2	Screw	Q235A	Electroplating yellow
1	Body	ZCuSn5Pb5Zn5	
No.	Description	Material	Remark
			JIS 7302-5K
			Note QTY Proportion
			A total of 1 first
			QingDeo V-gate Marine Valve Manufacturing Co.,LTD.

DRAWING

Process

Date

2015.17

QingDeo V-gate Marine Valve Manufacturing Co.,LTD.