

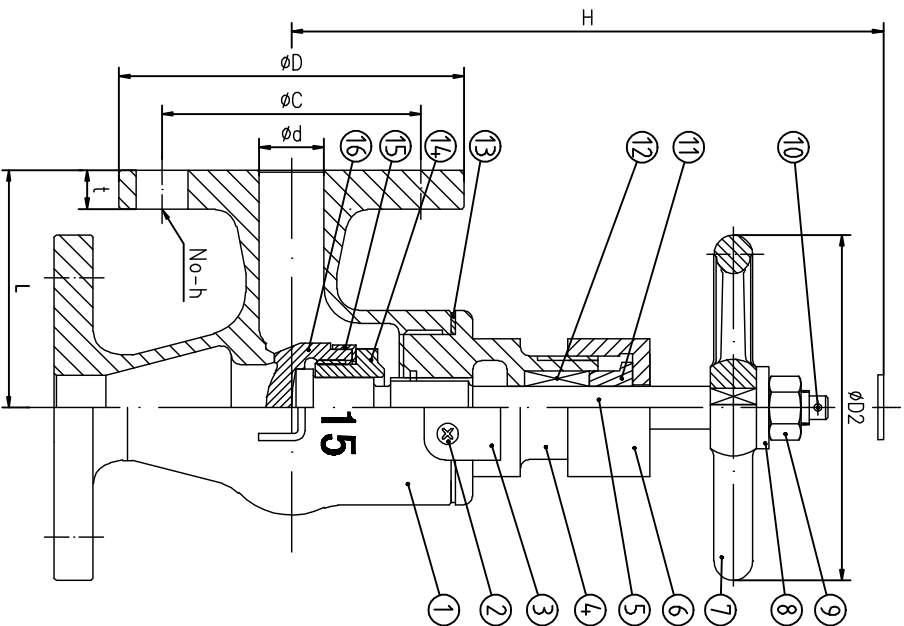

Marine Bronze Angle Valves 16K

Technical Specification

Nominal Pressure	Strength testing pressure	Seat testing pressure
16K	3.3MPa	2.42MPa



DN	d	L	D	C	No-h	t	H	D1	d1	a
15	15	70	96	70	4-15	12	120	80	T-14	4
20	20	75	100	75	4-15	14	130	100	T-16	4
25	25	85	125	90	4-19	14	145	125	T-18	4
32	32	95	135	100	4-19	16	150	125	T-18	5
40	40	100	140	105	4-19	16	165	140	T-20	6

16	Disc	H62	
15	Gasket	H62	
14	Disc Nut	H62	
13	Asbestos Free Graphite Packing	Expanded Graphite	
12	Graphite Packing	Expanded Graphite	
11	Gland Packing	H62	
10	Split Pin	A3	Electroplating yellow
9	Nut	Q235A	Electroplating yellow
8	Gasket Ring	Q235A	Electroplating yellow
7	Handwheel	HT200	
6	Gland nut	H62	
5	Stem	H62	
4	Cover	ZCuSn5Pb5Zn5	
3	Check Washer	H62	
2	Screw	Q235A	Electroplating yellow
1	Body	ZCuSn5Pb5Zn5	
No.	Description	Material	Remark
			JIS 7304-16K
			Note QTY Proportion
			A total of 1 first
Design	Fukewei	Review	
Calibrator	Fukewei	Approver	
Process		Date	2015.18

DRAWING