

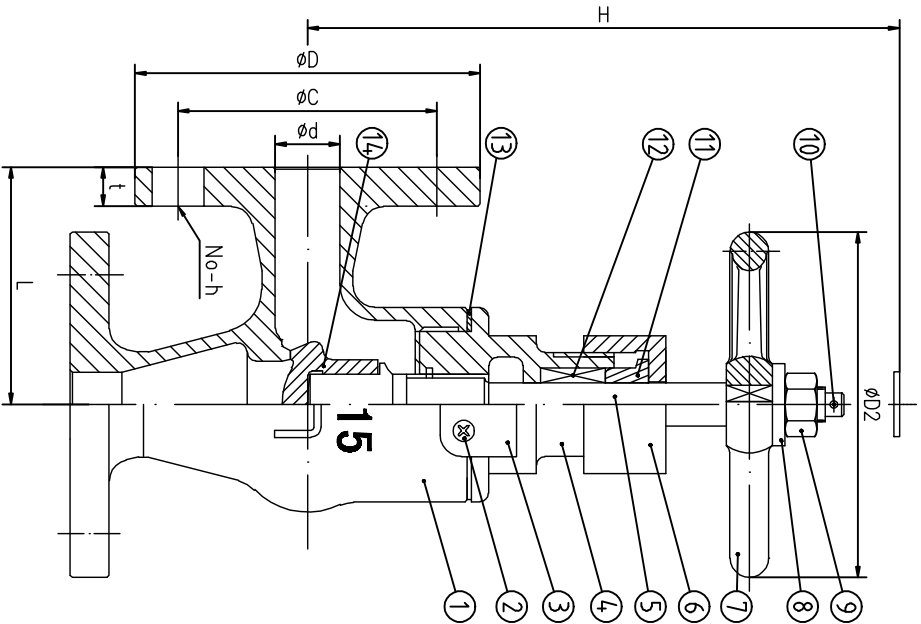

® Marine Bronze Screw Down Check Angle Valves 16K



| DN | d | L | D | C | No-h | t | H | D1 | d1 | a |
|----|----|-----|-----|-----|------|----|-----|-----|------|---|
| 15 | 15 | 70 | 95 | 70 | 4-15 | 12 | 120 | 80 | T-14 | 4 |
| 20 | 20 | 75 | 100 | 75 | 4-15 | 14 | 125 | 100 | T-16 | 4 |
| 25 | 25 | 85 | 125 | 90 | 4-19 | 14 | 140 | 125 | T-18 | 4 |
| 32 | 32 | 95 | 135 | 100 | 4-19 | 16 | 145 | 125 | T-18 | 5 |
| 40 | 40 | 100 | 140 | 105 | 4-19 | 16 | 160 | 140 | T-20 | 6 |

Technical Specification

| Nominal Pressure | Strength testing pressure | Seat testing pressure |
|------------------|---------------------------|-----------------------|
| 16K | 3.3MPa | 2.42MPa |

| 14 | Disc | H62 | |
|-----|------------------|-------------------|-----------------------|
| 13 | Asbestos Free | Expanded Graphite | |
| 12 | Graphite Packing | Expanded Graphite | |
| 11 | Gland Packing | H62 | |
| 10 | Split Pin | A3 | Electroplating yellow |
| 9 | Nut | Q235A | Electroplating yellow |
| 8 | Gasket Ring | Q235A | Electroplating yellow |
| 7 | Handwheel | HT200 | |
| 6 | Gland nut | H62 | |
| 5 | Stem | H62 | |
| 4 | Cover | ZCuSn5Pb5Zn5 | |
| 3 | Check Washer | H62 | |
| 2 | Screw | Q235A | Electroplating yellow |
| 1 | Body | ZCuSn5Pb5Zn5 | |
| No. | Description | Material | Remark |

| | | | |
|----------------|---------|--------------------|---------|
| JIS F74.10-16K | | A total of 1 first | |
| Note | QTY | Proportion | |
| Design | Fukewei | Review | |
| Calibrator | Fukewei | Approver | |
| Process | | Date | 2015.18 |

DRAWING