

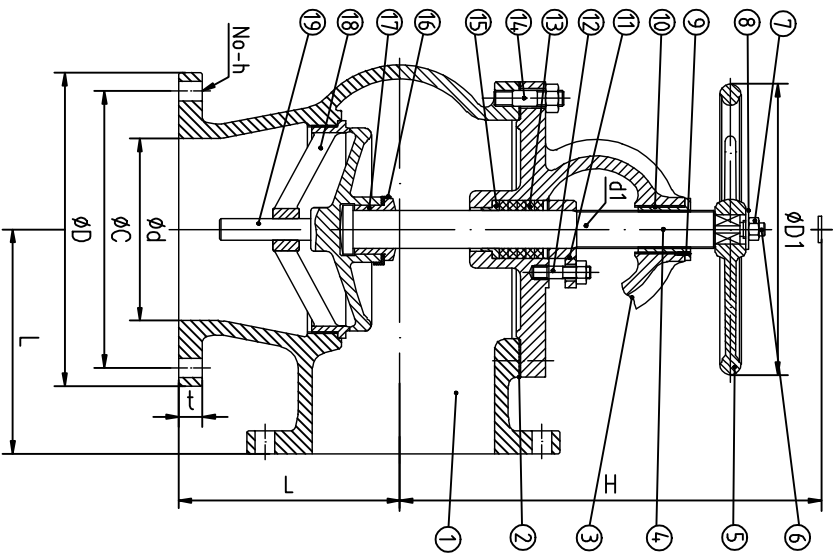

Marine Cast Steel Angle Valves 10K



DN	d	L	D	C	No-h	t	H	DI	d1	a
50	50	120	155	120	4-19	16	240	160	T-22	8
65	65	130	175	140	4-19	18	260	200	T-24	9
80	80	140	185	150	8-19	18	265	200	T-24	9
100	100	160	210	175	8-19	18	300	250	T-28	11
125	125	180	250	210	8-23	20	350	280	T-32	12
150	150	205	280	240	8-23	22	400	315	T-36	13
200	200	230	330	290	12-23	22	480	355	T-42	15
250	250	280	400	355	12-25	24	535	400	T-44	16
300	300	320	445	400	16-25	24	610	450	T-48	17

### Technical Specification

Nominal Pressure	Spec	Strength testing pressure	Seat testing pressure
10K	50L-300A	2.1MPa	1.5MPa

19	Disc	2Cr13	
18	Sealing Ring	2Cr13	
17	Disc Nut	2Cr13	
16	Check Washer	H62	
15	packing seat	H62	
14	Double Open end Bolt	Q235A	
13	Packing	Expanded graphite	
12	Double Open end Bolt	Q235A	
11	Gland Packing	2Cr13	
10	Screwed Bonnet Bush	H62	
9	Srew	Q235A	
8	Gasket Ring	Q235A	
7	Nut	Q235A	
6	Split Pin	A3	
5	Handhell	HT200	
4	Stem	2Cr13	
3	Cover	ZG230-450	
2	Asbestos Free	Expanded graphite	
1	Body	ZG230-450	
NO.	Description	Material	Remark

JIS 7320-10K

Note QTY Proportion

DRAWING

A total of 1 first

Design	Handle	NO.	Sign	Date
Fukewei				
Calibrator	Fukewei	Approver		
Process		Date	2014.12	

QingDeo V-gate Marine Valve Manufacturing Co., Ltd.