

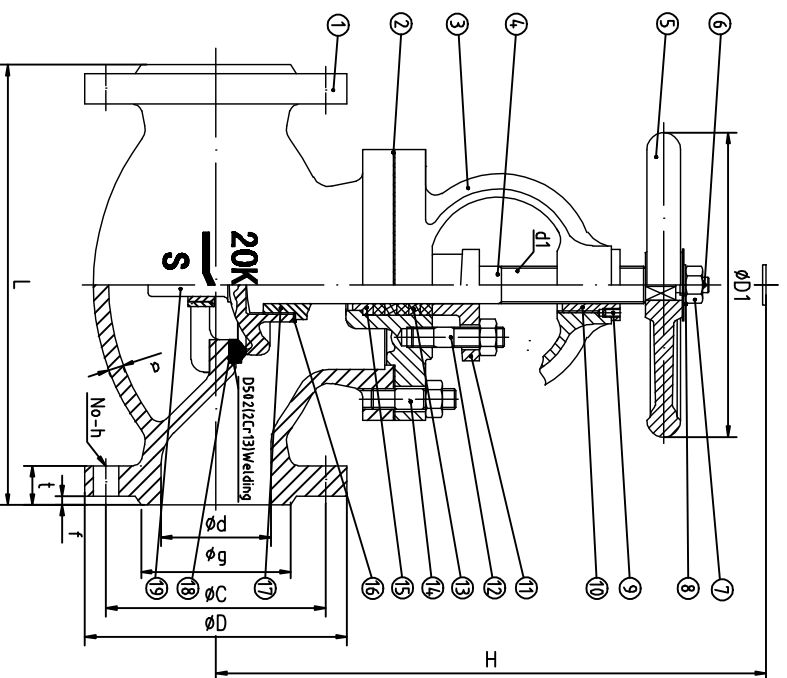

Marine Cast Steel Globe Valves 20K

Technical Specification

Minimal Pressure	Strength testing pressure	Seat testing pressure
20K	5.1MPa	3.74MPa



DN	d	L	D	C	No-h	t	g	f	H	D1	d1	a
32	32	190	135	100	4-19	18	80	2	270	160	Tr-20	8
40	40	200	140	105	4-19	18	85	2	290	160	Tr-22	9
50	50	230	155	120	8-19	18	100	2	305	200	Tr-24	9
65	65	270	175	140	8-19	20	120	2	345	224	Tr-26	10
80	80	300	200	160	8-23	22	135	2	385	250	Tr-30	11
100	100	350	225	185	8-23	24	160	2	440	280	Tr-34	13
125	125	430	270	225	8-25	26	195	2	500	315	Tr-38	14
150	150	500	305	260	12-25	28	230	2	550	355	Tr-42	16
200	200	560	350	305	12-25	30	275	2	630	450	Tr-50	17
250	250	660	430	380	12-27	34	345	2	725	560	Tr-58	19

19	Disc	2Cr13
18	Sealing Ring	D502 (2Cr13)Welding
17	Disc Nut	2Cr13
16	Check Washer	H62
15	packing seat	H62
14	Double Open end Bolt	Q235A
13	Packing	Expanded graphite
12	Double Open end Bolt	Q235A
11	Gland Packing	2Cr13
10	Screwed Bonnet Bush	H62
9	Screw	Q235A
8	Gasket Ring	Q235A
7	Nut	Q235A
6	Split Pin	A3
5	Handwheel	HT200
4	Stem	2Cr13
3	Cover	ZG230-450
2	Asbestos Free	Expanded graphite
1	Body	ZG230-450
NO.	Description	Material
JIS 7313-20K		Remark
A total of 1 First		
Note	QTY	Proportion
DRAWING		
Design	Fukewei	Review
Calibrator	Fukewei	Approver
Process	Date	2014.12
QingDeo V-gool Marine Valve Manufacturing CO.,LTD		