

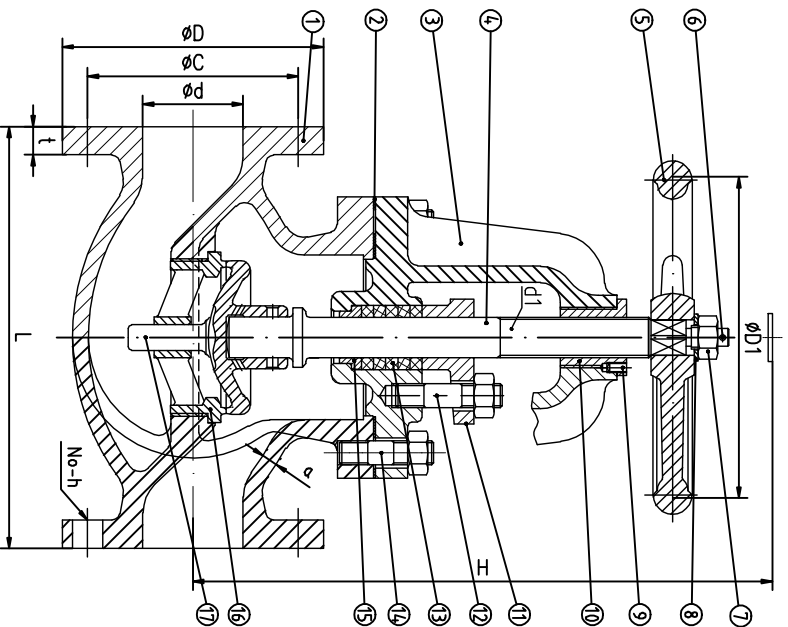

Marine Cast Steel Screw Down Check Globe Valves 5K



DN	d	L	D	C	No-h	t	H	DI	dI	a
50	50	210	130	105	4-15	16	270	160	Tr-20	8
65	65	250	155	130	4-15	18	290	180	Tr-22	9
80	80	280	180	145	4-19	18	300	180	Tr-22	9
100	100	340	200	165	8-19	20	350	224	Tr-26	10
125	125	410	235	200	8-19	20	380	250	Tr-28	11
150	150	480	265	230	8-19	22	430	280	Tr-32	12
200	200	570	320	280	8-23	24	505	315	Tr-36	15
250	250	740	385	345	12-23	26	620	355	Tr-42	16
300	300	840	430	390	12-23	28	715	400	Tr-46	17

Technical Specification

Nominal Pressure	Spec	Strength testing pressure	Seat testing pressure
5K	50-300	1.05MPa	0.77MPa

17	Disc	ZG-13	
16	Sealing Ring	ZG-13	
15	packing seat	H62	
14	Double Open end Bolt	Q235A	
13	Packing	Expanded graphite	
12	Double Open end Bolt	Q235A	
11	Gland Packing	ZG-13	
10	Screwed Bonnet Bush	H62	
9	Screw	Q235A	
8	Gasket Ring	Q235A	
7	Nut	Q235A	
6	Split Pin	A3	
5	Handwheel	HT200	
4	Stem	ZG-13	
3	Cover	ZG230-450	
2	Asbestos Free	Expanded graphite	
1	Body	ZG230-450	
NO.	Description	Material	Remark

Design	Fukewei	Review	Sign	Date
Calibrator	Fukewei	Approver		
Process		Date	2014.12	

DRAWING

JIS 7311C-5K
Note
QTY
Proportion

A total of 1 first

QingDeo V-gate Marine Valve Manufacturing Co., LTD.