

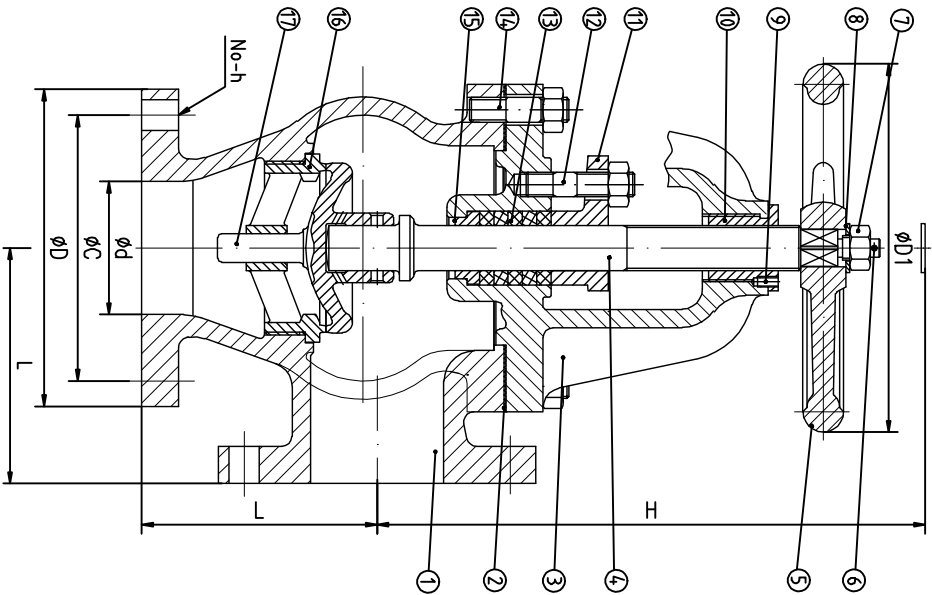

Marine Cast Steel Screw Down Check Angle Valves 5K



DN	d	L	D	C	No-h	t	H	D1	d1	a
50	50	100	130	105	4-15	14	240	160	Tr20	8
65	65	115	155	130	4-15	14	255	180	Tr22	9
80	80	130	180	145	4-19	16	265	180	Tr22	9
100	100	150	200	165	8-19	16	310	224	Tr26	10
125	125	170	235	200	8-19	16	330	250	Tr28	11
150	150	190	265	230	8-19	18	380	280	Tr32	12
200	200	220	320	280	8-23	20	450	315	Tr36	15
250	250	275	385	345	12-23	22	645	355	Tr42	17
300	300	310	430	390	12-23	22	750	400	Tr46	18

Technical Specification

Kind of Pressure	Spec	Strength testing pressure	Seat testing pressure
5K	50-300	1.05MPa	0.77MPa

17	Disc	2C-13	
16	Sealing Ring	2C-13	
15	packing seat	H62	
14	Double Open end Bolt	Q235A	
13	Packing	Expanded graphite	
12	Double Open end Bolt	Q235A	
11	Gland Packing	2C-13	
10	Screwed Bonnet Bush	H62	
9	Screw	Q235A	
8	Gasket Ring	Q235A	
7	Nut	Q235A	
6	Split Pin	A3	
5	Handwheel	HT200	
4	Stem	2C-13	
3	Cover	ZG230-450	
2	Asbestos Free	Expanded graphite	
1	Body	ZG230-450	
NO.	Description	Material	Remark

JIS 7312C-5K			A total of 1 first
Note	QTY	Proportion	
Design	Fukewei	Review	DRAWING
Calibrator	Fukewei	Approver	
Process		Date	
		2014.12	QingDeo V-gate Marine Valve Manufacturing CO.,LTD.