

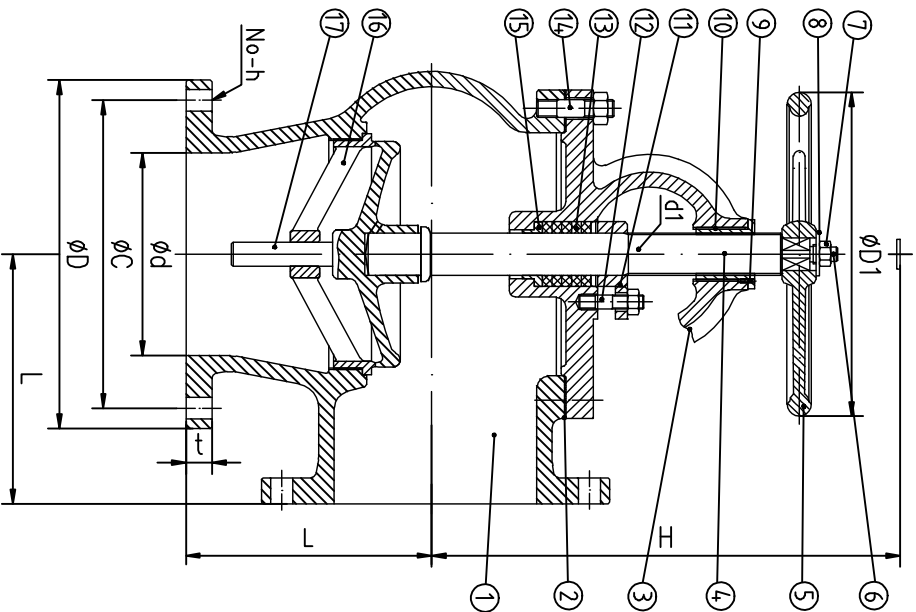

Marine Cast Steel Screw Down Check Angle Valves 10K



DN	d	L	D	C	No-h	t	H	DI	d1	a
50	50	120	155	120	4-19	16	240	160	Tx-22	8
65	65	130	175	140	4-19	18	260	200	Tx-24	9
80	80	140	185	150	8-19	18	265	200	Tx-24	9
100	100	160	210	175	8-19	18	300	250	Tx-28	11
125	125	180	250	210	8-23	20	350	280	Tx-32	12
150	150	205	280	240	8-23	22	400	315	Tx-36	13
200	200	230	330	290	12-23	22	480	355	Tx-42	15

Technical Specification

Nominal Pressure	Spec	Strength testing pressure	Seat testing pressure
10K	50A-200A	2.1MPa	1.54MPa

17	Disc	2C-13	
16	Sealing Ring	2C-13	
15	packing seat	H62	
14	Double Open end Bolt	Q235A	
13	Packing	Expanded graphite	
12	Double Open end Bolt	Q235A	
11	Gland Packing	2C-13	
10	Screwed Bonnet Bush	H62	
9	Screw	Q235A	
8	Gasket Ring	Q235A	
7	Nut	Q235A	
6	Split Pin	A3	
5	Handwheel	HT200	
4	Stem	2C-13	
3	Cover	ZG230-450	
2	Asbestos Free	Expanded graphite	
1	Body	ZG230-450	
NO.	Description	Material	Remark

Design			Fuhewei			Review			Sign			Date		
Calibrator			Fuhewei			Approver								
Process						Date			2014.12					
DRAWING												JIS 74.72-10K		
												A total of 1 first		
												QingDeo V-gate Marine Valve Manufacturing Co.,LTD.		