

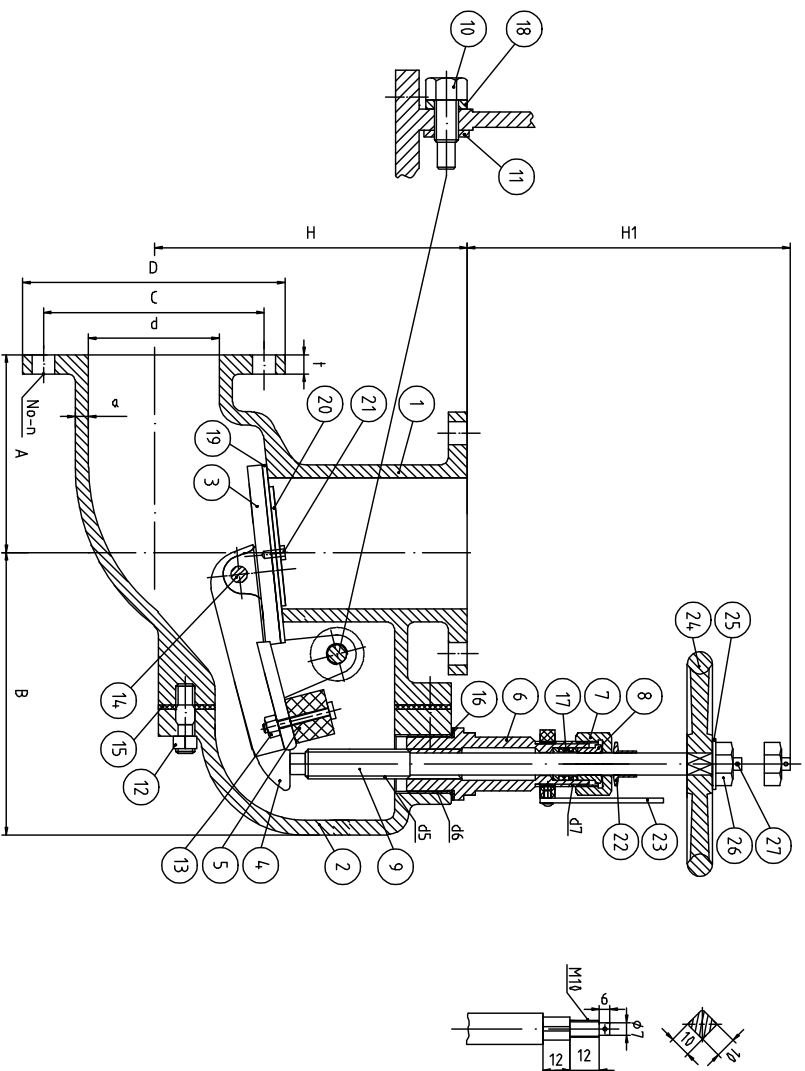

Cast steel Down Storm Anglee valves for Marine 5K/10K



Test pressure		
Nominal Pressure	Strength testing pressure	Seat testing pressure
5K/10K	0.5MPa	0.2MPa

DN	d	D	C	No-n	M	t	H	H1	A	B	a	d5	d6	d7
50	50	130	105	4-15	M12	14	170	187	90	135	8	TW20/M38X2	M36X2	M36X2
65	65	155	130	4-15	M12	14	200	175	110	145	9	TW20/M38X2	M36X2	M36X2
80	80	180	145	4-19	M16	14	220	180	120	155	9	TW20/M38X2	M36X2	M36X2
100	100	200	165	8-19	M16	16	250	175	130	175	10	TW20/M38X2	M36X2	M36X2
125	125	235	200	8-19	M16	16	270	192	150	195	11	TW20/M38X2	M36X2	M36X2
150	150	265	230	8-19	M16	18	310	187	165	215	12	TW20/M38X2	M36X2	M36X2

10k

DN	d	D	C	No-n	M	t	H	H1	A	B	a	d5	d6	d7
50	50	155	120	4-19	M16	16	170	187	90	135	8	TW20/M38X2	M36X2	M36X2
65	65	175	140	4-19	M16	18	200	175	110	145	9	TW20/M38X2	M36X2	M36X2
80	80	185	150	8-19	M16	18	220	180	120	155	9	TW20/M38X2	M36X2	M36X2
100	100	210	175	8-19	M16	18	250	175	130	175	10	TW20/M38X2	M36X2	M36X2
125	125	250	210	8-23	M20	20	270	192	150	195	11	TW20/M38X2	M36X2	M36X2
150	150	280	240	8-23	M20	22	310	187	165	215	12	TW20/M38X2	M36X2	M36X2

27	Split pin	A3
26	Nut	Q235A
25	Cushion	Q235A
24	Handwheel	FC200
23	Staff	H62
22	Staff	H62
21	Set screw for gasket	Q235A
20	Set plate for gasket	304
19	Gasket	EPDM
18	Gasket	Expanded graphite
17	Packing	Expanded graphite
16	Gasket	Expanded graphite
15	Gasket	Expanded graphite
14	Nut	H62
13	Nut	Q235A
12	Nut	Q235A
11	Washer	Expanded graphite
10	Valve axle	2Cr13
9	Spindle	2Cr13
8	Packing gland	H62
7	Packing gland nut	H62
6	Spindle box	H62
5	Counterweight	Pb
4	Closing arm for valve plate	H62
3	Valve plate	H62
2	Cover	ZG230-450
1	Body	ZG230-450
NO	Description	Material

DRAWING

JISF3060R-5K/10K

Qingdao V-gate Marine Valve Manufacturing Co., Ltd.