

# Top Flange

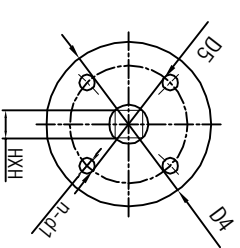
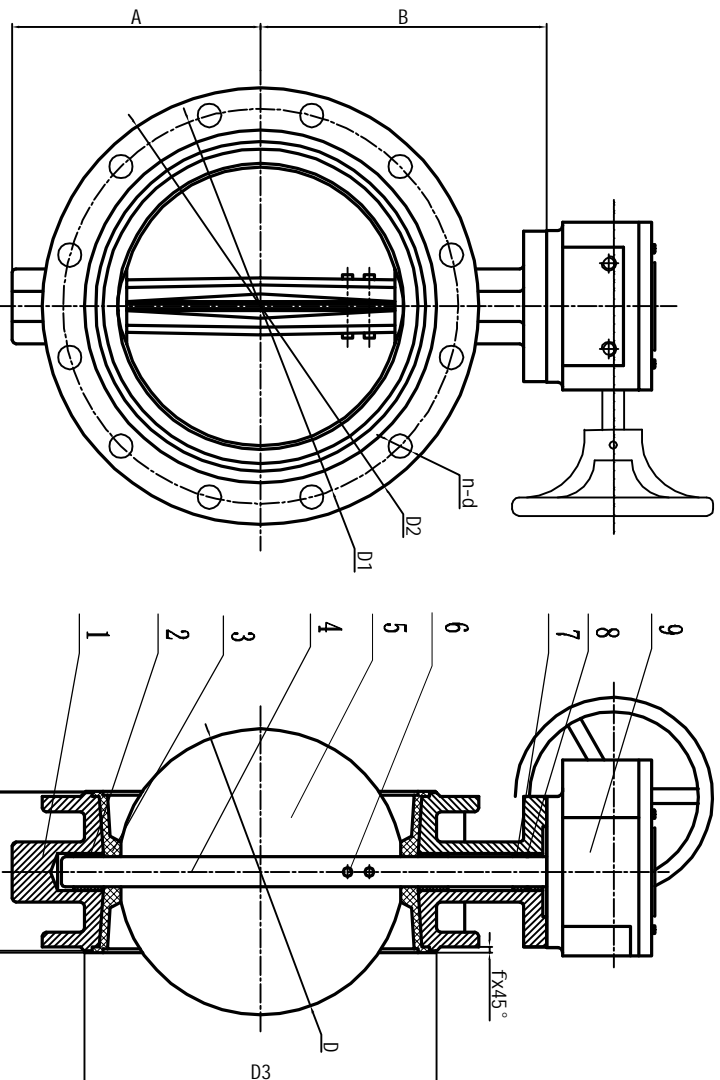

NO.	NAME	MATERIAL	QTY	SEAL
9	Gear box	DI	1	
8	O-Ring	NBR	1	
7	Short Bushing	PTFE	3	
6	Pin	SS410	2	
5	Disc	DI	1	
4	Shaft	SS410	1	
3	Seat	EPDM	1	
2	Long Bushing	PTFE	1	
1	Body	CI	1	

NO.	NAME	MATERIAL	QTY	SEAL
PRESSURE		SHELL		
HYDROSTATIC		15 Bar		11 Bar
AIR				
DESIGN CODE		BSS5155		
INSPECTION & TEST		ISO5208		
END STANDARD		ISO 7005 PN10		
FACE TO FACE		ISO5752		

TITLE :Double Flanged Butterfly Valve  
DN125

APPROVED		DWG NO.		REV
CHECKED				
DRAWN				
DESIGNED		SCALE	UNIT	mm

Size	A	B	D	D1	D2	n-d	D3	D4	D5	n-d1	L	L1	f	HXH
125	125	170	123.3	210	250	8-18	266	90	70	4-10	140	143	3	17X17

Qingdao V-Goal Marine Valve Manufacturing Co., Ltd.