

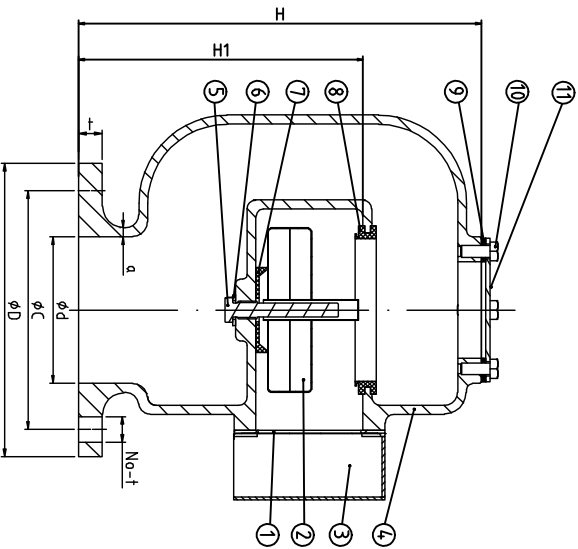

Air Pipe Head JIS-KS91A-121

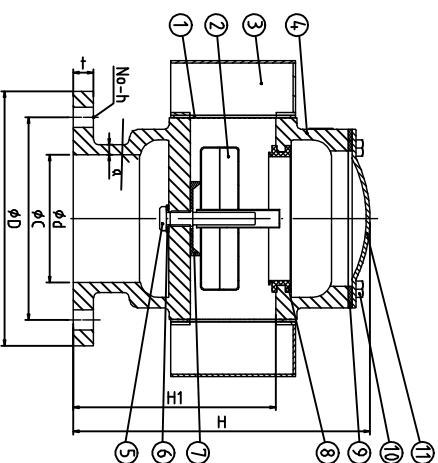

50A-80A

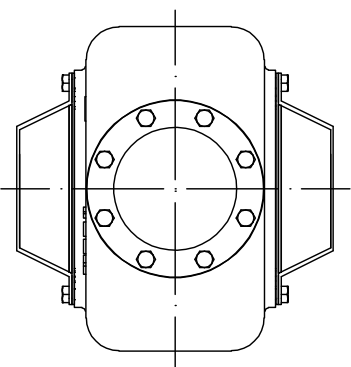

100A-400A

DN	d	D	C	No-h	HI	H	t	a
50	50	130	105	4-15	127	182	14	7
65	65	155	130	4-15	146	212	14	7
80	80	180	145	4-19	176	253	14	7
100	100	200	165	8-19	160	222	16	8
125	125	235	200	8-19	180	255	16	8
150	150	265	230	8-19	208	290	18	9
200	200	320	280	8-23	269	375	20	9
250	250	385	345	12-23	314	442	22	9
300	300	430	390	12-23	367	520	22	10
350	350	480	435	12-25	415	570	24	12
400	400	540	495	16-25	475	640	24	12
450	450	605	555	16-25	538	713	24	14

11	Cover	Q235	Galvanized
10	Hex Bolt	Q235	Galvanized
9	Cushion	NBR	
8	Rubber Ring	NBR	
7	Rubber Cushion	NBR	
6	Cushion	NBR	
5	Guide Bolt	304	
4	Body	HT200/QT450	
3	Screen	Q235	Galvanized
2	Float	304/316	
1	Flite	304	
NO	Description	Material	Remark
			JIS-KS91A-121
Note	Handle	NO.	Sign
Design	Fukewei	Review	Date
Calibrator	Fukewei	Approver	
Process		Date	2015.129
DRAWING			
A total of 1 First			QingDao V-good Marine Valve Manufacturing Co.,LTD.